

50t

All terrain

Type: Demag AC 50-1

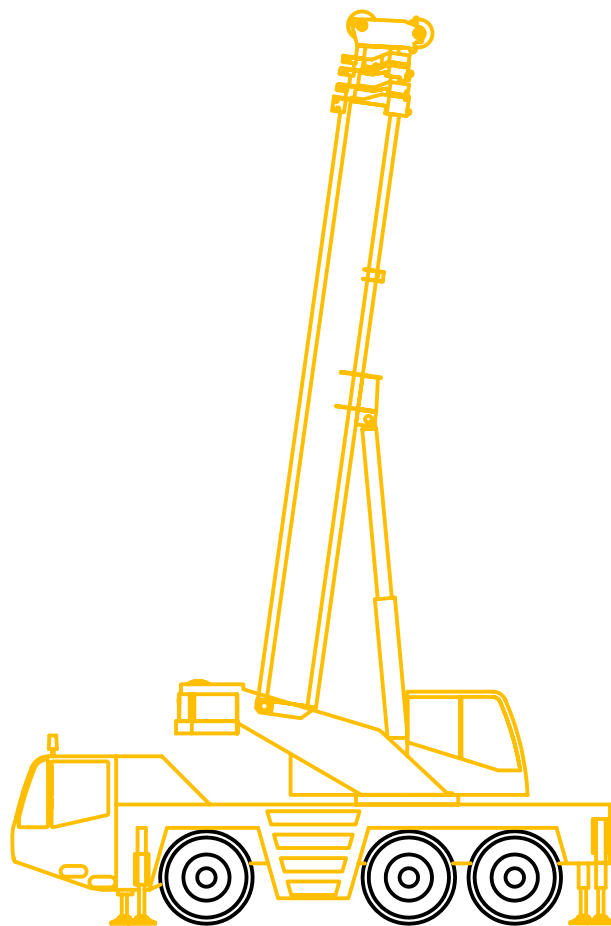

Demag AC 50-1

Hovedbom med 9,2m og 17,6m jib i 0°-20°-40°

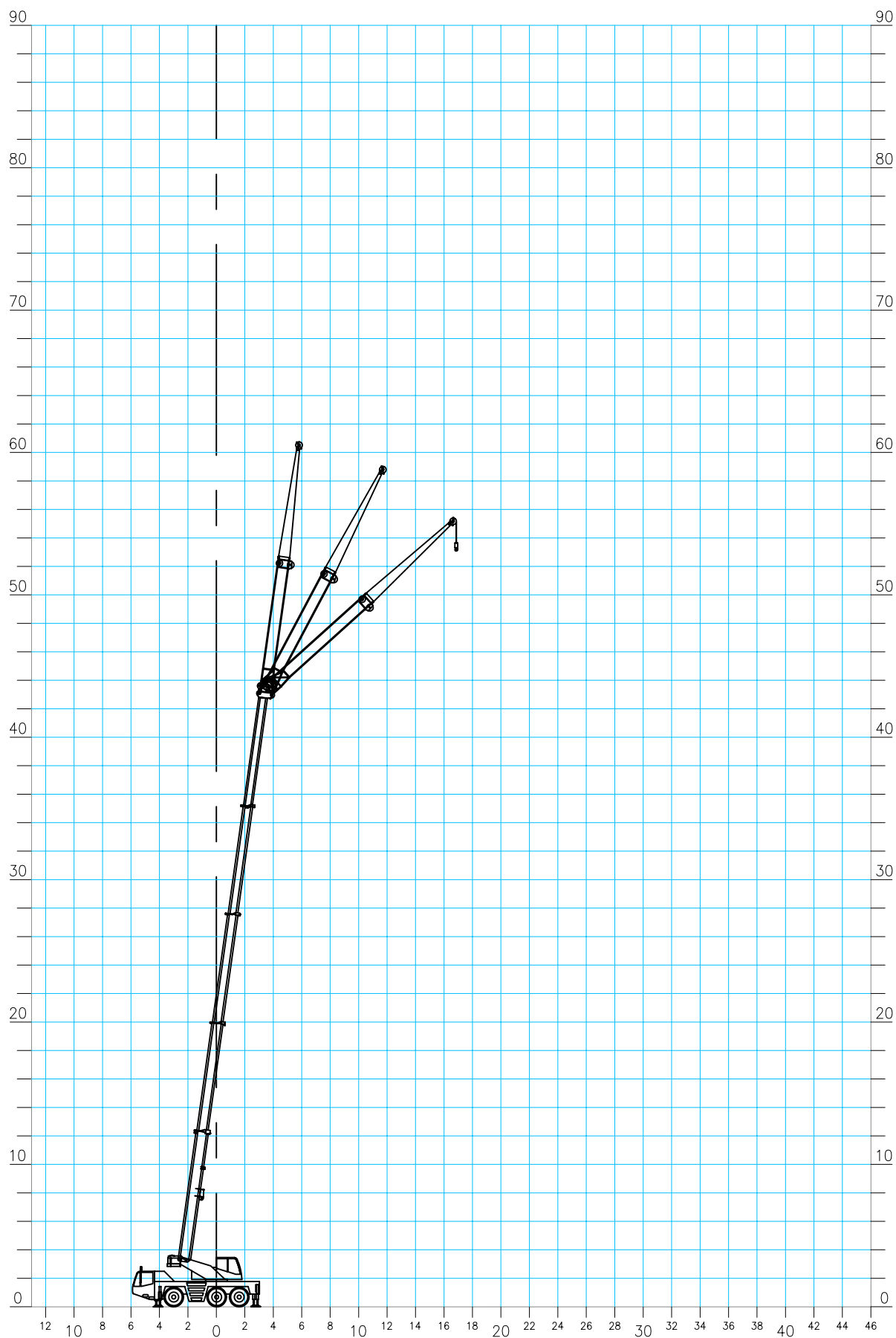

Krandata: **Løfteevne i tons**
 Type: **Demag AC 50-1, 50 tons mobilkran.**
 Løfteevne på: **Hovedbom.**
 Arbejds område: **Svingbar i 360°**
 Afstøtning: **Længde = 6,75m Normal bredde = 6,4m**
75% løfteevne i henhold til DIN 15019.2

Kontravægt i ton	9,5						
Bomlængde i m	10,1	16,1	22,1	28,0	32,5	37,0	40,0
Jiblængde i m							
Jibvinkel							
Udlæg							
2,5							
3,0	50,0 ¹						
3,5	45,7	28,0					
4,0	41,6	28,0	17,0				
4,5	38,1	28,0	17,0	14,0			
5,0	35,2	28,0	17,0	14,0	11,0		
6,0	32,6	25,0	17,0	14,0	11,0	9,0	
7,0	26,4	20,6	17,0	14,0	11,0	9,0	7,0
8,0	21,7	16,0	16,0	13,1	11,0	9,0	7,0
9,0		14,6	14,5	12,3	10,5	9,0	7,0
10,0		12,3	12,4	11,5	10,0	9,0	7,0
12,0		9,1	9,5	9,0	8,9	8,0	7,0
14,0			7,4	7,6	7,0	7,1	6,3
16,0			6,0	6,1	5,6	5,6	5,6
18,0			4,9	5,1	4,9	4,8	4,6
20,0				4,2	4,3	4,0	3,7
22,0				3,6	3,7	3,3	3,0
24,0				3,0	3,1	2,7	2,5
26,0					2,6	2,3	2,0
28,0					2,2	1,9	1,6
30,0						1,5	1,3
32,0						1,2	0,9
34,0							0,7
36,0							
38,0							
40,0							
42,0							
44,0							
46,0							
48,0							

1) Over bagende +/- 0°

Krandata: **Løfteevne i tons**
 Type: **Demag AC 50-1, 50 tons mobilkran.**
 Løfteevne på: **Hovedbom.**
 Arbejds område: **Svingbar i 360°**
 Afstøtning: **Længde = 6,75m Normal bredde = 6,4m**
75% løfteevne i henhold til DIN 15019.2

Kontravægt i ton	7,5						
Bomlængde i m	10,1	16,1	22,1	28,0	32,5	37,0	40,0
Jiblængde i m							
Jibvinkel							
Udlæg							
2,5							
3,0	50,0 ¹						
3,5	45,6	28,0					
4,0	41,5	28,0	17,0				
4,5	38,1	28,0	17,0	14,0			
5,0	35,1	28,0	17,0	14,0	11,0		
6,0	31,6	24,8	17,0	14,0	11,0	9,0	
7,0	25,5	18,6	17,0	14,0	11,0	9,0	7,0
8,0	19,6	16,0	16,0	13,1	11,0	9,0	7,0
9,0		13,3	13,1	12,3	10,5	9,0	7,0
10,0		11,1	11,5	11,0	10,0	9,0	7,0
12,0		8,2	8,6	8,7	8,2	8,0	7,0
14,0			6,6	6,8	6,3	6,3	6,3
16,0			5,3	5,5	5,5	5,2	4,8
18,0			4,3	4,5	4,5	4,2	3,8
20,0				3,7	3,7	3,4	3,0
22,0				3,1	3,1	2,8	2,4
24,0				2,6	2,6	2,2	1,9
26,0					2,2	1,8	1,5
28,0					1,8	1,4	1,2
30,0						1,1	0,8
32,0						0,8	
34,0							
36,0							
38,0							
40,0							
42,0							
44,0							
46,0							
48,0							

1) Over bagende +/- 0°

Demag AC 50-1

Hovedbom

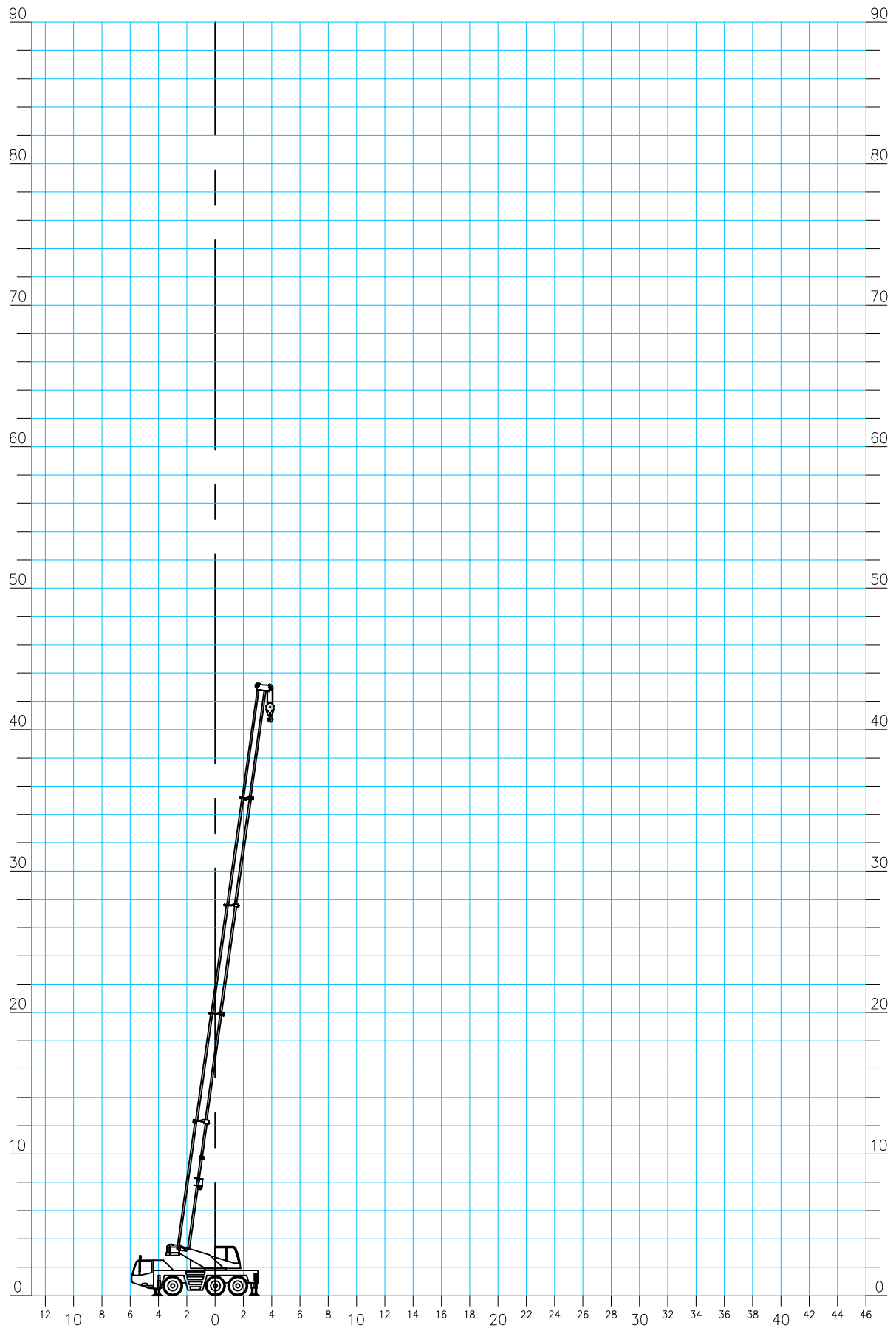

Krandata: **Løfteevne i tons**
 Type: **Demag AC 50-1, 50 tons mobilkran.**
 Løfteevne på: **37,0m hovedbom med 9,2m og 17.6m jib.**
 Arbejds område: **Svingbar i 360°**
 Afstøtning: **Længde = 6,75m Normal bredde = 6,4m**
75% løfteevne i henhold til DIN 15019.2

Kontravægt i ton	9,5					
Bomlængde i m	37,0					
Jiblængde i m	9,2			17,6		
Jibvinkel	0°	20°	40°	0°	20°	40°
Udlæg						
2,5						
3,0						
3,5						
4,0						
4,5						
5,0						
6,0						
7,0						
8,0	4,1					
9,0	4,1					
10,0	4,1			1,8		
12,0	4,1	3,7		1,8		
14,0	4,0	3,5	3,2	1,8		
16,0	3,9	3,4	3,1	1,8	1,8	
18,0	3,7	3,2	3,0	1,8	1,7	
20,0	3,5	3,1	2,9	1,8	1,6	
22,0	3,1	2,9	2,8	1,7	1,6	1,5
24,0	2,6	2,8	2,8	1,7	1,5	1,5
26,0	2,1	2,4	2,5	1,6	1,5	1,4
28,0	1,7	1,9	2,1	1,5	1,4	1,4
30,0	1,4	1,6	1,7	1,5	1,4	1,3
32,0	1,1	1,2	1,4	1,2	1,3	1,3
34,0	0,8	1,0	1,1	1,0	1,3	1,2
36,0	0,6	0,7		0,8	1,0	1,2
38,0					0,8	1,0
40,0					0,6	0,8
42,0						
44,0						
46,0						
48,0						

Krandata: **Løfteevne i tons**
 Type: **Demag AC 50-1, 50 tons mobilkran.**
 Løfteevne på: **40,0m hovedbom med 9,2m og 17.6m jib.**
 Arbejds område: **Svingbar i 360°**
 Afstøtning: **Længde = 6,75m Normal bredde = 6,4m**
75% løfteevne i henhold til DIN 15019.2

Kontravægt i ton	9,5					
Bomlængde i m	40,0					
Jiblængde i m	9,2			17,6		
Jibvinkel	0°	20°	40°	0°	20°	40°
Udlæg						
2,5						
3,0						
3,5						
4,0						
4,5						
5,0						
6,0						
7,0						
8,0						
9,0	3,1					
10,0	3,1			1,1		
12,0	3,1	3,1		1,1		
14,0	3,1	3,1		1,1		
16,0	3,1	3,0	2,9	1,1	1,1	
18,0	3,1	2,9	2,8	1,1	1,1	
20,0	3,1	2,7	2,6	1,1	1,1	
22,0	3,0	2,6	2,5	1,1	1,1	1,1
24,0	2,5	2,5	2,4	1,1	1,1	1,1
26,0	2,1	2,3	2,3	1,1	1,1	1,1
28,0	1,7	1,9	2,1	1,1	1,1	1,1
30,0	1,3	1,5	1,7	1,1	1,1	1,1
32,0	1,0	1,2	1,3	1,1	1,1	1,1
34,0	0,8	0,9	1,0	0,9	1,1	1,1
36,0	0,6	0,7	0,8	0,7	1,0	1,1
38,0					0,8	1,0
40,0					0,6	0,7
42,0						
44,0						
46,0						
48,0						

Demag AC 50-1

Målskitse i millimeter.

Kranen er vist med fuld kontravægt.

Akseltryk: 12,0 ton.

Totalvægt: 36,0 ton.

Krogdata		
Kapasitet	Vægt	Nødstop
30,1 ton	370 kg	1800 mm
12,9 ton	250 kg	1800 mm
14,3 ton	130 kg	800 mm
-	-	-
-	-	-

